

stageClix

JACK 5.8

User manual

Version 4.0 06/2016

English

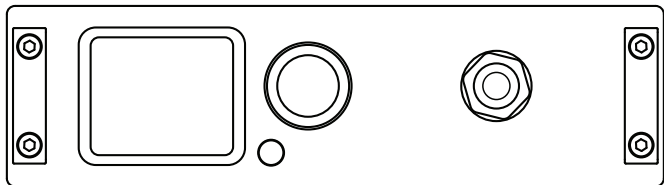
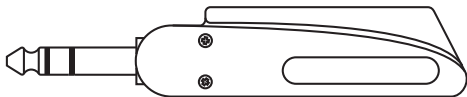

A word of thanks

Thank you for choosing stageClix! This unit has been designed with the professional musician in mind.

All units are made with only the best-quality components and are produced using RoHS-compliant materials. This means they do not contain any harmful substances, like lead or mercury. In stageClix, we have developed a highly effective system that can be used for your favourite instruments or headset/mics.

If you have any questions, please e-mail them to us at support@stageclix.com

If you like your stageClix product, please like us on Facebook and on Instagram.

Safety

Do not open; no user-serviceable parts inside

Warranty void when opened.

Do not use phantom power.

Unit is not waterproof; keep away from water and other liquids.

The maximum operating temperature of this unit is 55°C.

Keep away from electric heaters and flames.

Clean using a damp cloth.

Do not use cleaning agents or solvents.

Contents

1. What's in the box?	1
2. Using stageClix for the first time	2
3. Controlling the receiver	3
4. Changing channels	5
5. Other settings	6
6. Controlling the transmitter	7
7. Signal quality	8
8. Technical details	9
9. Warranty	10
10. Conformities	11

1. What's in the box?

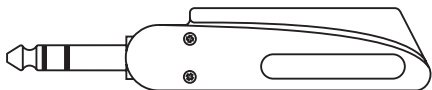

Transmitter

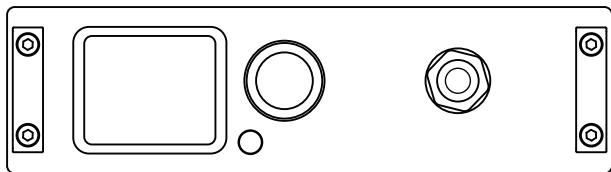

Receiver

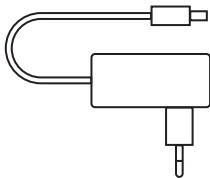

Power adapter

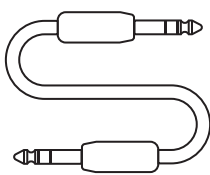

Patch cable

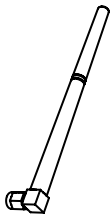

5.8 GHz antenna

2. Using stageClix for the first time

1. Attach the antenna to the back of the receiver by turning the nut clockwise.
(Do not use tools, and do not over-tighten)
2. Plug the supplied mains adapter into a 110-230V power supply, and the DC plug into the rear-panel DC socket. Only use the stageClix power supply.
3. Use the supplied patch cable to connect the rear-panel output jack to your amplifier input or to the input of your effects unit.
4. Plug the transmitter into the front socket marked 'charge' and leave the transmitter to charge for some time, preferably more than one hour.

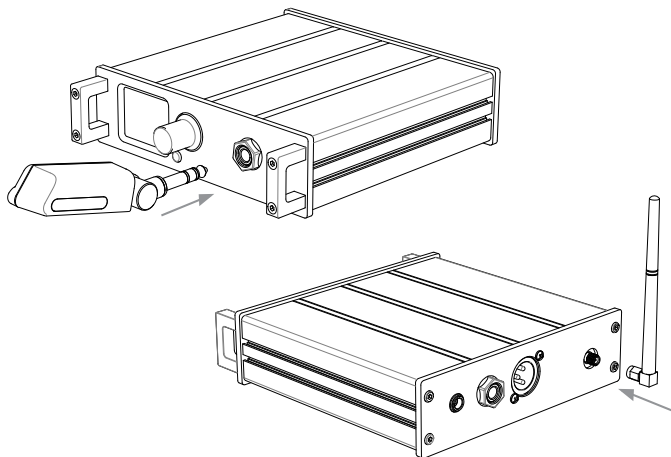

3. Controlling the receiver

Receiver controls

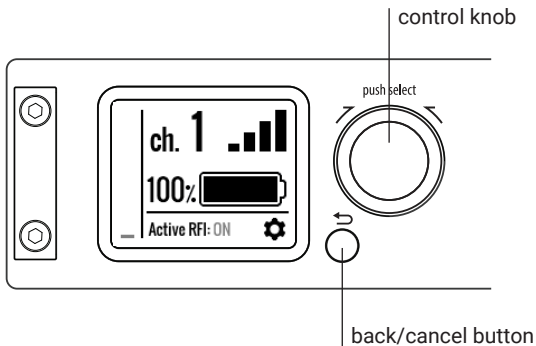

Display items

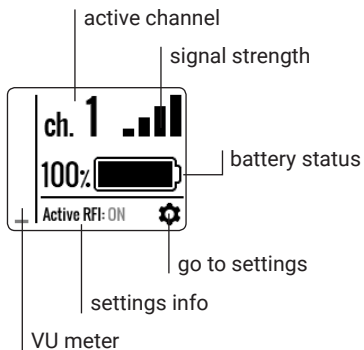

You can change settings on the receiver by using the control knob. Rotate to change, and push to confirm your action. You can go back or cancel at any time by pressing the back/cancel button.

To enter changes, start by pressing the control knob once. This will highlight the channel number, and a short help text will be displayed.

Rotate the button to choose between the highlighted settings icon and the highlighted channel number.

Press the button again to change the highlighted item.

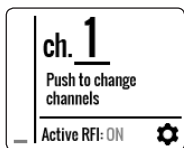

highlighted channel

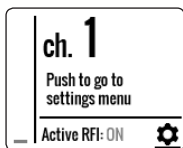

highlighted settings

The highlighted item will automatically revert to the non-highlighted state after a few seconds. You can also press the back button to achieve this.

4. Channels

If you are going to be using more than one stageClix unit simultaneously in the same venue, you will need to be able to switch between channels. To do this, follow the procedure below, which will also help you resolve any compatibility/interference issues with other equipment:

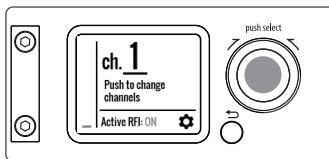

Press the control knob to activate channels.

Press the control knob again to change channels.

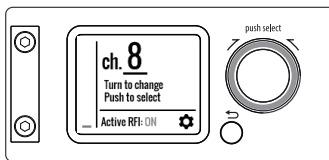

Rotate the control knob to choose another channel.

Press the control knob to confirm selection of this channel.

Leave the transmitter plugged into the receiver to keep it synchronized with the receiver while changing channels. When the transmitter is not plugged in, you can automatically synchronize it by plugging it into the receiver.

5. Other settings

In the settings menu, you can change the following:

Brightness - Adjust the brightness of the display during normal operation. (When the receiver is used, the display will switch to full brightness.)

Invert display - Choose between a white and a black background.

Active RFI - Active RFI reduces interference with guitar electronics or piezo pickups.

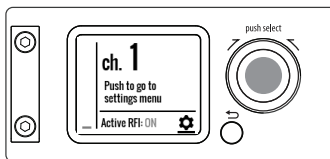

Press the control knob to activate channels; rotate to select settings.

Press the control knob to enter the settings menu.

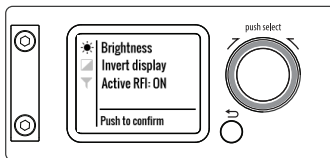

Rotate the control knob to choose between items.

Press the control knob to change a highlighted item.

6. Controlling the transmitter

The transmitter can be switched on and off using the button.

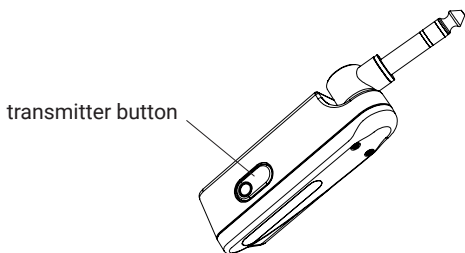

When you unplug the transmitter from the receiver, it will automatically switch off. To reactivate the transmitter, press the button.

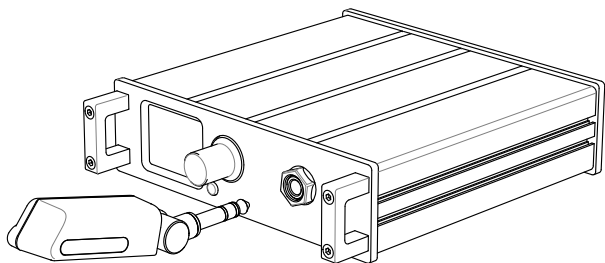

Plug the transmitter into the receiver to charge it and synchronize the channel settings.

7. Signal quality

- If possible, install the receiver in an elevated position, such as on top of an amplifier.
- Avoid broadband interference sources like WiFi access points or WiFi-enabled laptops, and switching power supplies.
- For maximum range, keep the antenna away from other cables and ensure it is pointing upwards if possible.
- Stone walls and reinforced ferro-concrete walls can partially block the signal.
- This system uses a patented digital transmission technique and unique triple-frequency diversity for a reliable noise-free link.
- This set contains a transmitter which is legal to sell in the EU. Some countries may restrict use.
- Refer to www.ero.dk for conformity information.

8. Technical details

Receiver

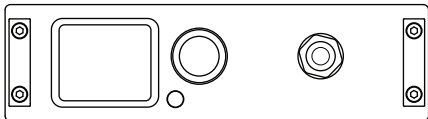

- Full aluminium enclosure
- Rackmount-ready
- Power supply: 9V 1A
- Receiving frequency: 5.8 GHz band (5.725 GHz - 5.850 GHz)
- Receiver sensitivity: -82dBm
- Bitstream audio DAC

Transmitter

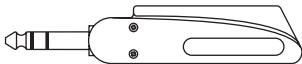

- High-quality (industrial) lithium polymer battery: 950mAh
- Polycarbonate housing
- Transmitter frequency: 5.8 GHz band (5.725 GHz -ss 5.850 GHz)
RF output power: 25mW
- Input impedance: 4.7 megohm
- Input capacitance: <100pF
- ESD-protected
- No compander
- Bitstream audio ADC
- Frequency response: 10Hz-21KHz ± 3 dB @100mVpp

9. Warranty

The stageClix product you have purchased is covered by a warranty for a term of 24 months, commencing on the date of purchase. Please retain your sales receipt as proof of purchase.

We shall satisfy our warranty obligations by remedying any material or manufacturing faults free of charge at our discretion, either by repair or by exchanging individual parts or the entire appliance.

This warranty does not cover the following:

- Minor faults or deviations in the quality of the product which do not affect the product's value or suitability for its intended purpose.
- Faults resulting from improper use, e.g. operating errors, mechanical damage, incorrect operating voltage. Proper use for the purpose of this warranty is defined as use of the product in compliance with the conditions stated in these instructions for use.
- Faults arising from normal wear and tear.

The purchaser bears the cost and risk of return shipment to the point of sale.

Warranty claims can be made in any country whose statutory rights are not in conflict with our warranty regulations. No other warranty claims or claims over and above those stated in these terms and conditions will be accepted.

10. Compliances

CE declaration of conformity

This unit has been tested in accordance with the R&TTE Directive:

- ETSI EN 300440-2 (Radio)
- EN 301 489 V1.4.1 (EMC)
- EN 60950 (Safety)

Manufacturer declarations

This unit is compliant with the Restriction of Hazardous Substances (RoHS) Directive.

Handle and dispose of the transmitter and receiver with care.

- To replace the batteries, contact stageClix or an authorised stageClix dealer.
- Incompatible batteries or charging using any device other than the stageClix receiver can cause serious injuries or damage to your stageClix product.
- Never throw the transmitter or receiver on a fire.
- Follow all local regulations when disposing of this product.
- Never place the transmitter or receiver on or in a heating device, such as a microwave oven, stove, or radiator. The transmitter contains batteries that may explode when overheated.
- Never crush or puncture the transmitter or receiver. Avoid exposing the transmitter and receiver to high external pressure, which can lead to an internal short circuit and overheating.
- Protect the product from damage.
- Avoid exposing the transmitter and receiver to very low or very high temperatures (below 0°C/32°F or above 45°C/113°F). Extreme temperatures can reduce the battery life of the transmitter.
- Never use a damaged transmitter or receiver.

Ensure maximum battery and charger life

- Avoid charging the transmitter for more than a week, as continuous charging may shorten battery life.
- Over time, unused batteries will discharge. Do not allow the batteries to fully discharge over time, since this can cause them damage.
- Charge the transmitter before use.
- Disconnect the receiver from power sources when not in use.
- Use the transmitter only for its intended purpose.

Correct disposal of this product

(Waste Electrical & Electronic Equipment)

(Applicable in the European Union and other European countries with separate collection systems)



If the product, accessories or literature bear this mark, it means that the product should not be disposed of with other household waste at the end of its working life. To prevent possible harm to the environment or human health from uncontrolled waste disposal, please separate these items from other types of waste and recycle them responsibly to promote the sustainable reuse of material resources. Household users should contact either the retailer from whom they purchased this product, or their local government office, for details on where and how they can take these items for environmentally safe recycling.

Commercial users should contact their supplier and check the terms and conditions of the purchase contract. This product and its electronic accessories should not be mixed with other commercial waste for disposal.

www.stageclix.com
The Netherlands

stageClix is a trademark of QDES Works BV. QDES Works BV shall in no event be liable for damages arising from use of this product.